

Functional description

For use as a monitoring and alarm system for exhaust flows in various applications, such as fume hoods, safety cabinets and other extraction units.

A microprocessor controlled security system for monitoring the containment-safe operating status of fume hoods. An acoustic and optical alarm is activated as soon as the exhaust flow falls below or exceeds the programmed threshold values.

FM100 fulfills the standard EN 14175. That means security for the laboratory worker. FM100 is suitable for all fume hood constructions, making it easy to carry out new installations and re-fittings on existing fume hoods. In addition to client-specific designs a wide range of different function displays are available (see the data sheet Standard function displays).

A suitable measurement system is vital for precise and safe monitoring. For safe operation with the static differential pressure transmitter and reproducible and exact measurement results we recommend the SCHNEIDER venturi measuring tube or measuring tube.

Function and control panel

The function and control panel is available with its own case or as a built-in version in different variations. Client-specific designs are implemented quickly and cost-effectively.

Functions:

- Acoustic and optical alarm (red LED) for insufficient exhaust/supply air
- Optical display (green LED) for sufficient exhaust/supply air
- RESET button to acknowledge the acoustic alarm
- Plug for programming via the service module SVM100 or laptop

Options:

- Button light ON/OFF (fume hood interior)
- Optical display (yellow LED) when the maximum exhaust air is exceeded
- Yellow blinking LED as an optical alarm for the operating status "Sash > 50cm"



Performance features

- microprocessor controlled monitoring system
- integrated power supply 230V AC
- all system data are saved mains voltage failure-safe in the EEPROM
- separate terminal board for fast, simple cable connection
- pluggable main board for easy setup
- programming of all system values via service module SVM100 or laptop computer software PC2000
- monitoring of supply and exhaust air systems
- static differential pressure transmitter with long-term stability. Measuring range: 6...240 pascal or 20...800 pascal. Optionally with air flow sensor (face velocity)
- monitoring of fume hood operation to EN 14175 with acoustic and optical alarms
- optional monitoring of exceedance of a programmable volume flow with optical alarm
- optical and optional acoustic alarm for the operating status "Sash > 50cm"
- programming of a second monitoring value (reduced volume flow during night-time operation)
- emergency power pack (optional) for mains voltage failure-safe operation
- integrated battery pack charging connection with low voltage disconnect
- suitable for all fume hood constructions

Schematic diagram: Fume hood monitoring system FM500

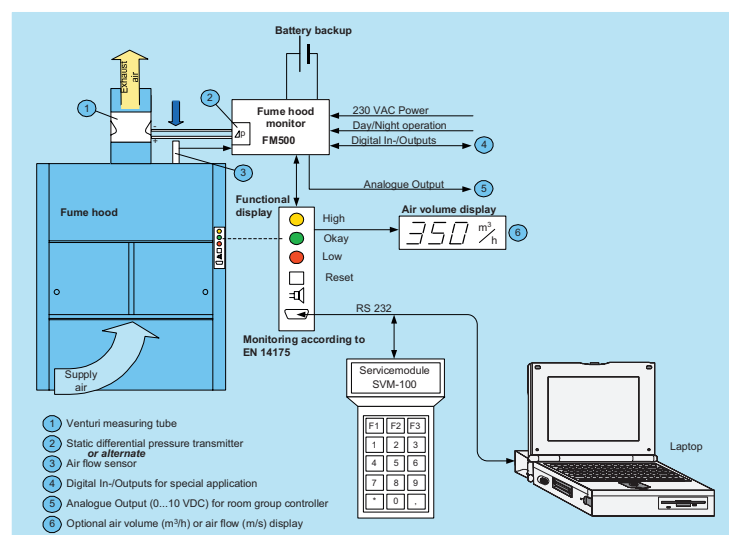

Order code: fume hood monitoring system

Order code: Fume hood monitoring system

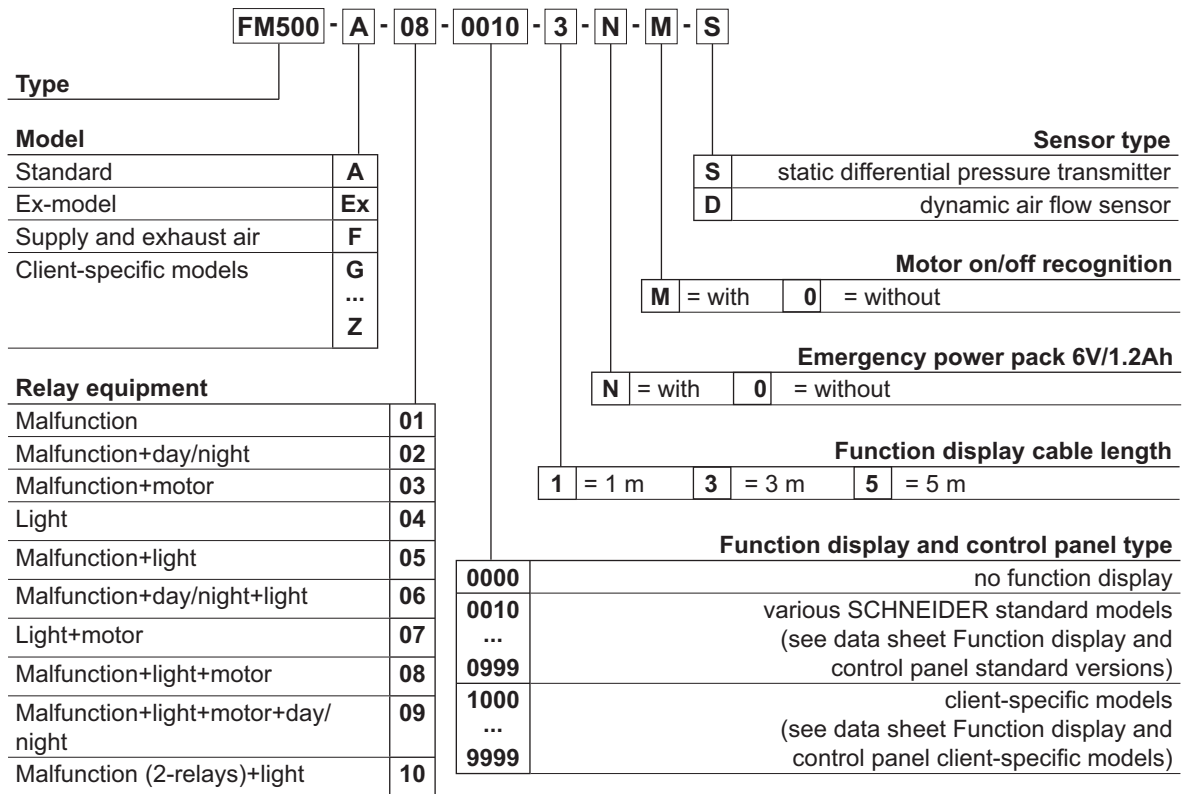

Ex-protected model:

With ex-differential pressure transmitter and ex-barrier, suitable for zone 2 and zone 1. Mount the FM500 basic model outside the ex-zone. Venturi measuring tube or measuring tube is absolutely essential and to be ordered separately.

Ordering example: Fume hood monitoring system FM500

Case construction=standard, 3 relays, function display and control panel type = 0010 with 3m cable, with emergency power pack, with motor on/off recognition, static differential pressure transmitter.

Make: SCHNEIDER

Type: FM500-A-08-0010-3-N-M-S

Order code: Venturi measuring tube

VM - 250 - P - MM		
Type		Pipe connections
Nominal diameter [mm]		Inflow Outflow
DN 160	160	MM Socket Socket
DN 200	200	FF Flange Flange
DN 250	250	MF Socket Flange
DN 315	315	FM Flange Socket
Material		
Polypropylene (PPs)	P	
PPs electroconductive (Ex-model)	Pel	
FM 4910	F	
Galvanised steel	S	
Stainless steel V4A	V	

Ordering example: Venturi measuring tube
DN250, PPs, Socket/socket

Make: SCHNEIDER Type: VM-250-P-MM

Order code: Measuring tube SCHNEIDER

MT - 250		
Type		Lengths [mm]
	160	160, 200, 250
	...	315, 400, 500
	800	600, 700, 800

Ordering example: Measuring tube
Length 250 mm, PP, suitable for DN250 or angled air ducts (width=250 mm)

Make: SCHNEIDER Type: MT-250

Terminal diagram

Terminal diagram: Fume hood monitoring system FM500

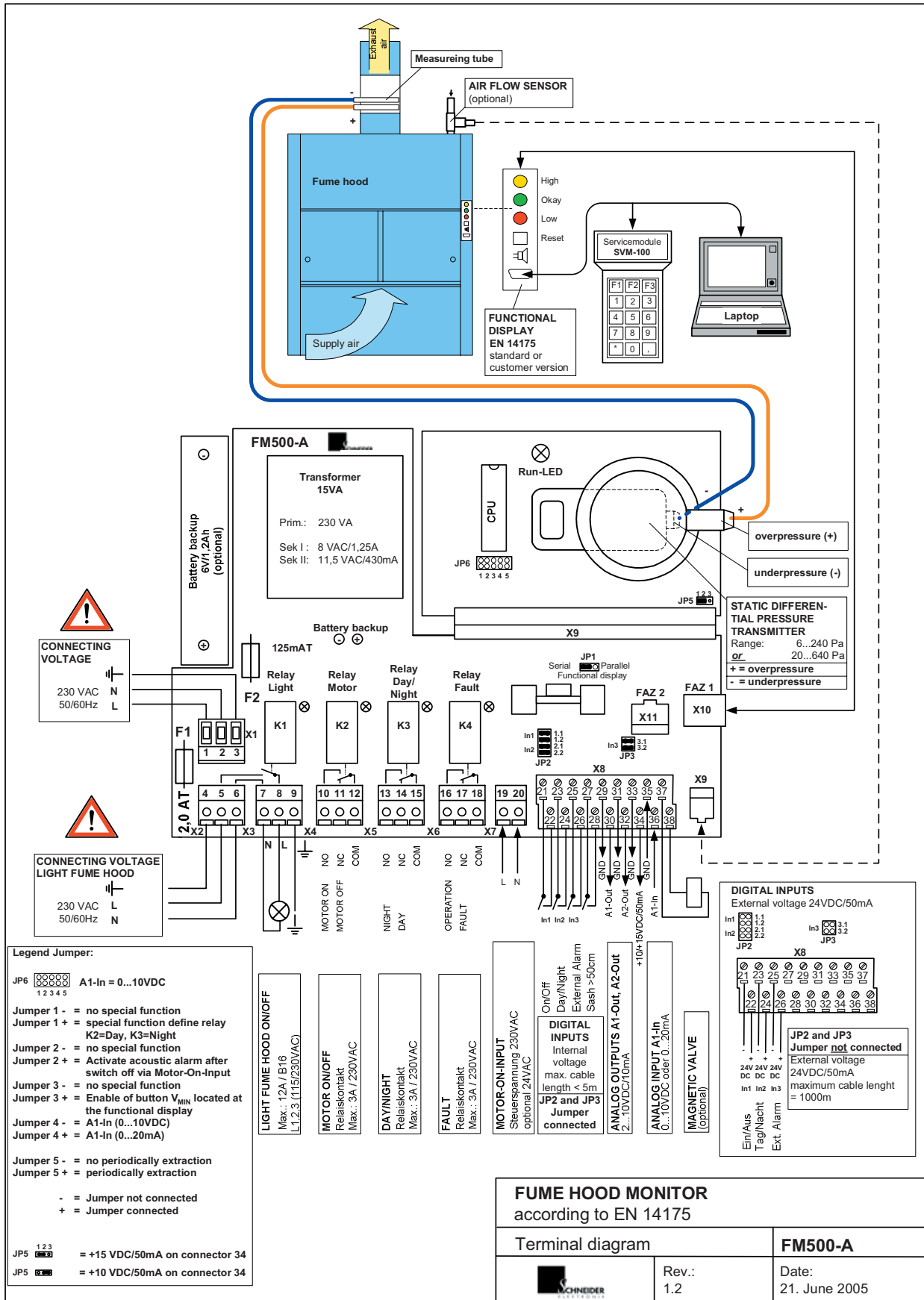

■ General	
Nominal voltage	230V AC/50/60Hz/±15%
Max. charging rate	200 mA
Max. power input	15 VA
Reactivation time	600ms
Operating temperature	0 °C bis +55 °C
Humidity	max. 80 % relative, non-condensing

■ Case	
Protection type	IP 20
Material	sheet steel
Colour	white, RAL 9002
Dimensions (LxWxH)	(225 x 205 x 90) mm
Weight	ca. 2.8 kg
Terminals	screw terminal 1.5 mm ² caged spring terminal 1.5 mm ²

■ Relay outputs	
Number	1 relay (K1)
Contact type	front contact
Max. switching voltage	250V AC
Max. continuous current	12A
Number	3 relays (K2, K3, K4)
Contact type	changeover contact
Max. switching voltage	250V AC
Max. continuous current	3A

■ Digital inputs	
Number	3 opto-couplers
Max. input voltage	24V DC ±15%
Max. input current	10mA (per input)

■ Analogue output	
Exhaust air actual value	2...10VDC, 10mA
Exhaust air setpoint value	2...10VDC, 10mA

■ Analogue input	
Setpoint value	0(2)...10VDC, 1mA

■ Differential pressure transmitter	
Measuring principle	static
Pressure range	6...240 pascal 20...800 pascal optional
Response time	<10 ms
Overpressure max.	500 mbar

■ Optional measurement system	
Material	polypropylene (PPs)
Measurement system	venturi measuring tube or measuring tube

Case FM500: Top view

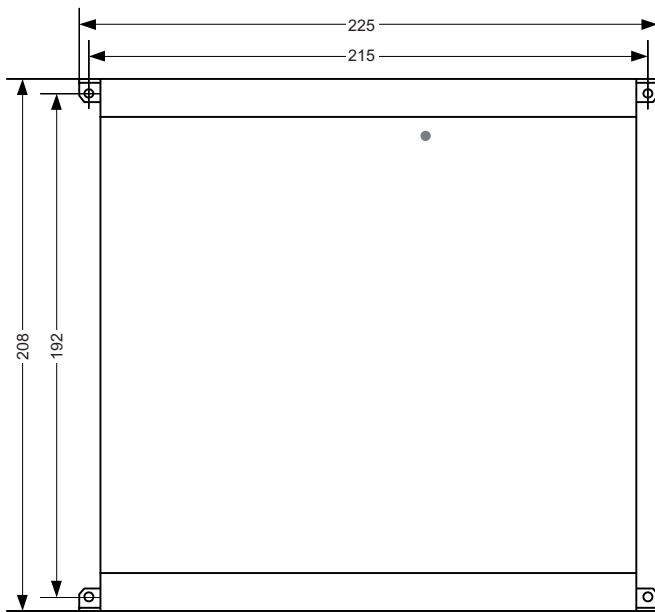

Case FM500: Side view

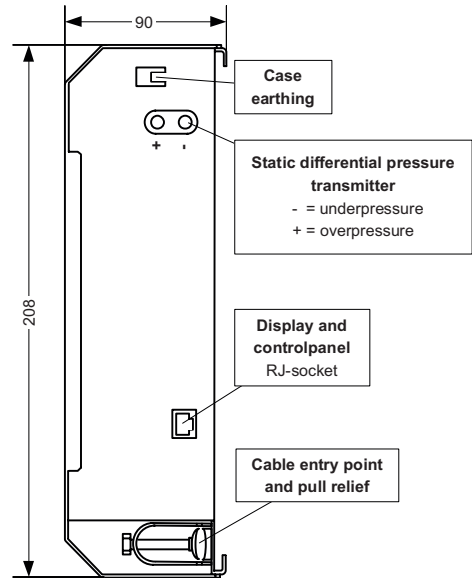

Venturi measuring tube

Construction: PP, socket/socket

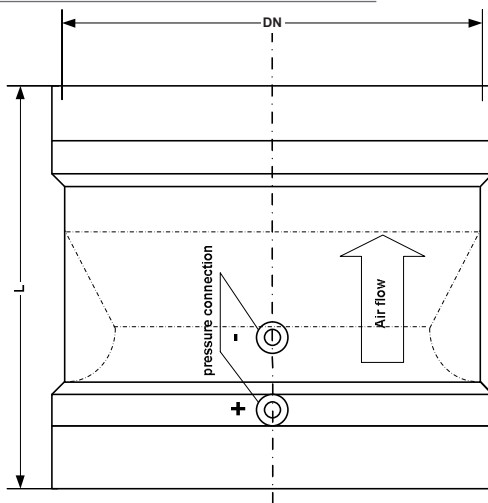

Nominal diameter [mm]	Length [mm]	Shield factor B	V _{MIN} [m ³ /h]	V _{MAX} [m ³ /h]
DN 160	190	40	80	509
DN 200	210	61	120	798
DN 250	230	92	180	1263
DN 315	600	148	280	2025

Shield factor B related to air density 1,2 kg/m³

Tender specification FM500

Fume hood monitoring system with integrated microprocessor, two independent watchdog circuits and static differential pressure transmitter. Monitoring of fume hood operation to EN 14175 with acoustic and optical alarm. Optical and optionally acoustic alarm for the operating status "Sash > 50cm open". Integrated charging connection with low voltage disconnect for emergency power pack. Optional monito-

SCHNEIDER Standard function display

Function display type: 0010



Measuring tube SCHNEIDER

Suitable for fitting in pipes or angled air ducts
Construction: PP, lengths from 160 to 800 mm



The shield factor B for the measuring tube MT has to be calculated and is depending on the mounting position.

ring of exceedance of a programmable air flow with optical alarm and parameter setting of a second monitoring value (reduced air flow during night-time operation). System data storage in mains voltage failure-safe EEPROM. Separate terminal board for fast, simple cable connection. Suitable for all fume hood constructions.

Subject to change without prior notice • All rights reserved © SCHNEIDER